

multidata

Installation and operating manual
changeover heating/cooling meter
or calculators for cooling meters only
with 2 additional inputs/outputs
optionally with M-Bus, RS 232 and RS 485



General information

With multidata you have acquired one of the most up-to-date, modern heat calculator currently available on the market.

The calculator for changeover heating/cooling meters can be identified by the inscription "change over" on the front of the body, the cooling meters by the inscription "cooling". Calculators for heating meters only don't have any specific inscription. Expressive symbols in the display and easy menu navigation make readout simple.

It can be operated with one single button. The setting of the data loggers (depending on the

type of device) is being done via the software GMM.

The calculator is equipped with a long-life battery made for operation during the initial verification validity period (5 years) including a reserve of at least another year. With a second battery you will reach 11 years.

Initial verification

The heating energy metering part of the multidata is manufactured and tested according to the new European Measuring Instrument Direc-

Technical data	
Temperature range	°C 1 - 150
Temperature difference range	k 3 - 120
Display	Multifunctional LCD, 8-digit, floating
Display unit	MWh, kWh, GJ, MJ
Interface flow sensor	Models with contact pulsers or active pulser (No Namur or Opto, Passive max 1hz/ active max. 100Hz)
Temperature sensor connection	PT500, optional PT100, PT1000
Max. cable length temperature sensor 2 wire	12.5 m (PT500), 2.5 m (PT100), 20 m (PT1000)
Max. cable length temperature sensor 4 wire	20 m
Interfaces	optical, optionally ZR-Bus (RS 485), M-Bus, RS 232, remote readout outputs
Ambient temperature	°C 5 - 55
Power supply	Battery 3.6 V Lithium, optionally mains power supply 230V/24V
Battery lifetime	6 years, optionally 11 years
Protection class	IP 54 / IP 65, acc. to DIN 40050
Mechanical/electro-magnetic class	M1/E1
Accuracy class	according to EN1434
Measuring cycle dynamic	40s/30s/10s

tive. The Year of the Declaration of Conformity is specified with the EC conformity mark (e.g. M10). The cooling energy metering part is manufactured and tested according to the instructions of the PTB Instruction TR K7.2. The initial verifi-

cation stamp informs about the year of the first calibration (e.g. 10).

For legal metrology devices, the national regulations still apply within the EU. The duration of initial verification validity in Germany remains 5

Technical data flow sensor input

Flow sensor input

Electrical connection

Schematic diagram

Connection data

Passive with mechanical contact (Reed)



1 Hz Version: $f_{max} = 1$ Hz, Pulse-duty factor 1:1 to 1:9 Input capacitance: approx. 10 nF, Input resistance approx 850 kOhm
100 Hz Version: not allowed

Passive with open drain FET

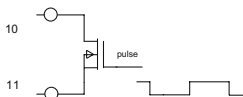

1 Hz Version: $f_{max} = 1$ Hz, Pulse-duty factor 1:1 to 1:9 Input capacitance: approx. 10 nF, Input resistance approx 850 kOhm
100 Hz Version: $f_{max} = 30$ Hz, Pulse-duty factor 1:1 Input capacitance: approx. 2,5 nF, Input resistance approx. 850 kOhm

Active f.ex. with C-MOS Gate

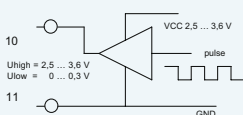

1 Hz Version: $f_{max} = 1$ Hz, Pulse-duty factor 1:1 to 1:9 $U_{high} = 2,5 \dots 3,6$ V, $U_{low} = 0 \dots 0,3$ V, Input capacitance: approx. 10 nF, Input resistance approx 850 kOhm
100 Hz Version: $f_{max} = 100$ Hz, Pulse-duty factor 1:1 $U_{high} = 2,5 \dots 3,6$ V, $U_{low} = 0 \dots 0,3$ V, Input capacitance: approx. 2,5 nF, Input resistance approx. 850 kOhm

Technical data additional inputs

Electrical connection

Schematic diagram

Connection data

Passive with mechanical contact (Reed)



$f_{max} = 1$ Hz,
Pulse-duty factor 1:1 to 1:9
Input capacitance: approx. 15 nF,
Input resistance approx 470 kOhm

Passive with open drain FET

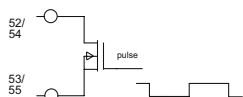

$f_{max} = 1$ Hz,
Pulse-duty factor 1:1 to 1:9
Input capacitance: approx. 15 nF,
Input resistance approx 470 kOhm

Connection data outputs

Typical connection*

Ext. Voltage
Max. current

3V ... 30 V DC
20 mA



Output frequency

1 Hz (8 Hz dynamically switching, if output with 1 Hz is not possible)

Switching times:

1 Hz: 400ms < t_p < 600 ms
8 Hz: 50ms < t_p < 80 ms

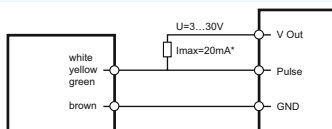

(*) The connection of the external resistor could be necessary to ensure an integrated current limiter

years for heat meters. After this period has expired, the measuring device may no longer be used for billing in commercial use. The regulations resp. validity period may vary in other countries of the EU.

Electro-magnetic interference

multidata fulfills the national and international requirements for interference resistance. To avoid malfunctions due to other interferences, do not install fluorescent lamps, switch cabinets or electric devices such as motors or pumps in the immediate vicinity of the meter (minimum distance 1 m). Cables leaving the meter should not be laid parallel to live cables (230V, minimum distance 0.2 m).

Declaration of Conformity

ZENNER International GmbH & Co. KG declares that this product with the number of the EC type-examination certificate DE-08-MI004-PTB012 complies with the requirements of the directives 2014/32/EU (Measuring instruments directive) and 89/336/EEC (electro-magnetic compatibility). The most up-to-date information about this product and of our installation notice can be found at www.zenner.com

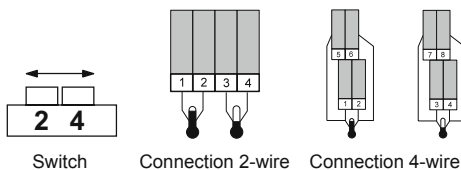

Connector pin assignment

Temperature sensors

2-wire measurement

Supply	1 - 2
Return	3 - 4

4-wire measurement (optionally)

Supply	1 - 2 / 5 - 6
Return	3 - 4 / 7 - 8

Flow sensor

Flow sensor pulse	10
GND	11

M-Bus

M-Bus	L1	24
	L2	25

Input/Output

I/O 1	pulse	52
	GND	53
I/O 2	pulse	54
	GND	55

RS-232

DTR	71
GND	72
Tx	73
Rx	74

RS-485

+UB	71
GND	72
A	73
B	74

Depending on the model the version of the connection board can differ.

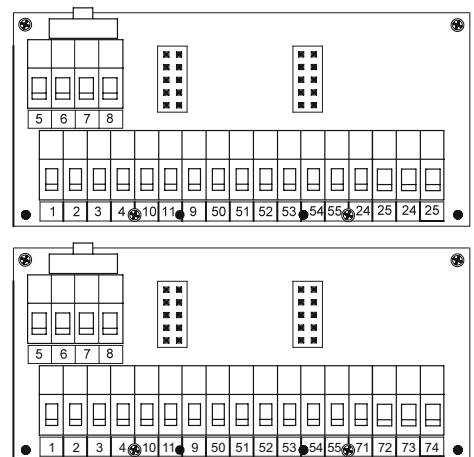

If water meters with a potential free reed contact are connected to the inputs there are free of polarity.

Take care of the polarity when the pulse outputs are connected to BMS.

The connectors are given twice for the incoming and outgoing of the M-bus wire.

Dimensions	
Height:	H = 106 mm
Width:	B = 126 mm
Depth:	T = 54 mm

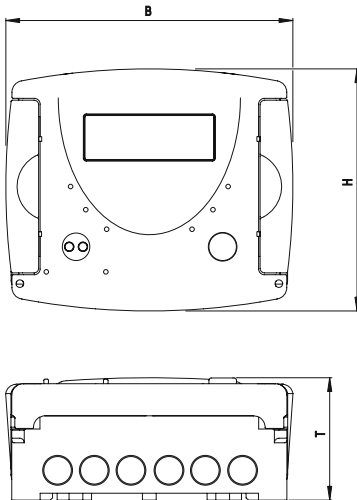

Communication

At calculators for changeover heating/cooling meters the first pulse output (I/O 1) gives the heating energy and the second output (I/O 2) the cooling energy information.

The pulse value is permanently set and corresponds with the last position of the associated display value.

Example:

Output 1 = energy output

Energy display = XXXXX.XX MWh

Last position = 0.01 MWh = 10 kWh

Output pulse = 10 kWh

The calculator can be ordered with two inputs optionally. The pulse value can be called up in the display (see the display overview, Level 1).

M-Bus (optional)

The optional M-Bus interface complies with the norm EN 1434-3 and operates with 2400 baud fixed. It can be set to 300/9600 baud if necessary. The display resolution shall be selected such that the display can not run over within a period of one year.

Installation instructions

Safety instructions

The installation has to be done by qualified personnel. Read the instructions carefully right up to the end before starting to mount the device.

The current laws and regulations have to be observed, especially EN 1434 part 1+6, (in Germany also AGFW directive FW202 and DIN 4713 part 4 and the initial verification directive).

At devices with communication interfaces or mains supply the general technical rules and the correspondent regulations have to be followed.

While demounting flow sensors and temperature sensors make sure no heating water escapes from the pipe – **this can cause burns!**

Close valves and release pressure before installation.

General Information

Take care of:

- the display must readable at all times
- to avoid malfunctions due to other interferences do not install fluorescent lamps, switch cabinets or electric devices such as motors or pumps in the immediate vicinity of the meter (minimum distance 1 m)

- all welding must be finished
- the ambient temperature must not exceed 55°C
- the type of temperature sensor must correspond with the calculator
- the pulse value of the flow sensor must correspond with the one from the calculator

At cooling meters for use within German metrology all the components must be calibrated and labelled accordingly.

For use as changeover heating/cooling meters all the components must be labelled both for EC conformity declaration and or national initial verification.

The calculator has 7 screwed cable glands for wires with a diameter between 4.2 and 10 mm. Keep unused glands closed.

Mind the connection order: temperature sensors first, flow sensor afterwards!

multidata is delivered ready for operation. It does not need any settings or adjustments.

ZENNER International GmbH & Co. KG

Römerstadt 6

D-66121 Saarbrücken

Telefon +49 681 99 676-30

Telefax +49 681 99 676-3100

E-Mail info@zenner.com

Internet www.zenner.com

Installation heat calculator

ZENNER recommends to mount the calculator on the wall. Do not mount the device at the pipe or attach it directly on the flow sensor.

The mounting adapter at the backside of the calculator can be used for rail mounting or for wall mounting.

For wall mounting detach the adapter and turn it 180°, attach with at least two screws to the wall and clip the calculator on it.

For rail mounting lift the adapter a little bit, place the calculator on the rail and push the adapter back until it locks.

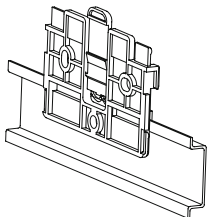

Rail mounting

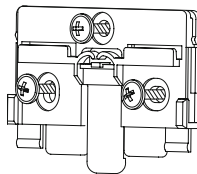

Wall mounting

Connection sensors

The mounting of the temperature sensors should be done symmetrical with direct immersion. If immersion sleeves are used they have to be checked for conformity to MID and have to be marked accordingly. The installation of immersion sleeves has to be done according to DIN EN 1434-2.

- The sensor cables are marked with colors (red = supply, blue = return with respect to the heating system).
- Do not buckle, extend or shorten the wires!
- Do only use paired sensors with the same serial number on it.
- At 2-wire systems the cable length of the temperature sensor for supply and return should not exceed 2.5 m for PT100, 12.5 m for PT500 and 20m for PT1000.
- At 4-wire systems the maximum cable length is 20 m.
- Consider EN 1434-2 regarding the diameter of the wires.
- Supply and return sensors must be inserted into the immersion sleeves completely.
- Installation points in the flow sensor can be used for symmetrical installation of the temperature sensors
- Seal temperature sensor after installation to prevent unauthorized demounting (seals included).
- Do not wrap or install wires along hot pipes.
- **Attention!** At the versions with temperature sensor type TS-45-5 (see type plate at the sensor cable) both sensors must be always immersed directly in contact with the heat conducting fluid. The installation in sensor pockets is not allowed.

Switch 2-/4-wire

Calculators equipped with 4-wire measuring system can be switched to 2-wire with the switch on the top left side of the connection board.

Switch to the left for 2-wire, switch position on the right for 4-wire measurement.

Connection flow sensor

The total length of the wire between flow sensor and calculator should not exceed 10 m.

With mechanical flow sensors the connection order is not relevant.

Mind the polarity at electronic flow sensors.

External power supply

A small vertical line appears in the display when the optional external power supply is on service. In case of a failure of the external power supply the device switches automatically to battery supply.

The battery lifetime can be checked in the display (level 3). After having reached the date the battery has to be replaced if needed.

Operation test

Check the changeover heating/cooling meters after installation for any error code (installation error); errors see table for error codes. Most of the errors can be deleted by pressing the button. If the error appears permanently, it will be detected at the next measuring cycle and displayed again. Check whether the volume information is updated and the displayed temperatures correspond to the present ones while the system is running (measuring cycle 2 minutes max.).

When attaching the top cover on the housing pulses on the inputs can possibly be generated. Check readings of the inputs and correct if necessary.

Sealing

Seal the device with the included seals to prevent unauthorized opening.

Maintenance

Repairs or overhaul are only allowed by the manufacturer or companies authorized by the manufacturer.

Care instructions





Clean plastic surfaces with a damp cloth only.

Do not use any scouring or aggressive cleaning

The device is maintenance-free during the service life.

Status display / Error codes

The symbols in the table below show the meter's operational status. The status messages only appear in the main display (energy)! The temporary display of the warning triangle can be caused by special operating states and does not always mean that the device is malfunctioning. However, should the symbol be displayed over a longer period of time you should contact the service company.

Symbol	Status	Event
	Flow existent	-
	Attention!	Check system / device for errors
	Data transmission	-
	Emergency operation	Exchange device
	External power supply	-

Error codes show faults detected by multidata. If more than one error appears, the sum of the error codes is displayed: Error 1005 = error 1000 and error 5.

Code	Error	Event
1	Short-circuit return sensor	Check sensors, replace if needed
2	Interruption return sensor	Check sensors, replace if needed
3	Short-circuit supply sensor	Check sensors, replace if needed
4	Interruption supply sensor	Check sensors, replace if needed
5	Hardware error	Exchange device
6	Battery empty or wrong temp. sensor	Check device / sensor
7	Temperatures out of measuring range	Correction heating system
100	Emergency operation	Exchange device
1000	Battery life time exceeded	Exchange device
2000	Initial verification expired	Exchange device
> 8000	Internal hardware error	Exchange device

Display menu

Level 1

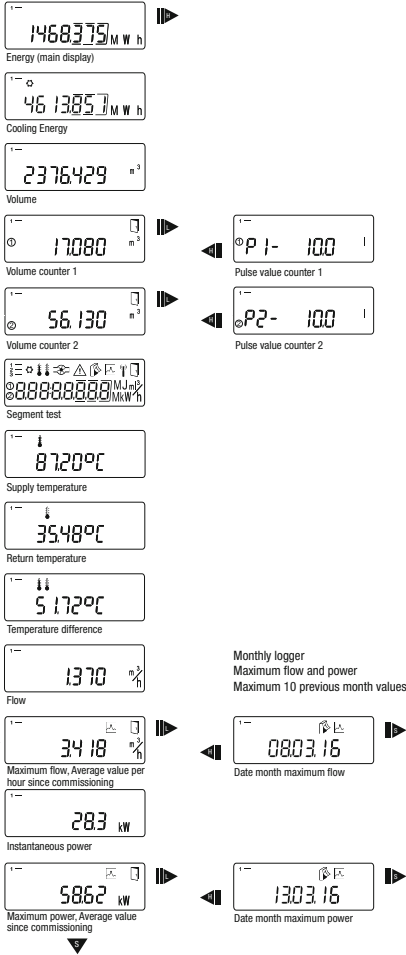

Level 2

You can switch levels at any point in the menu.

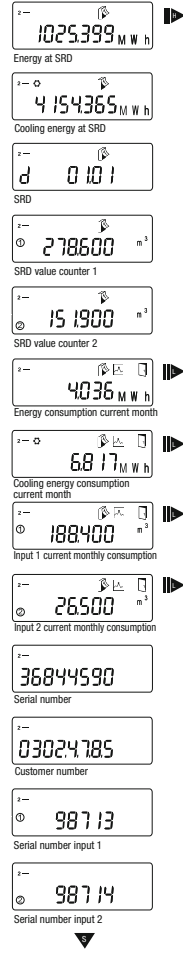

Note

Depending on your multi-data its displays can differ in number and order from those shown here.

Level 3

Back to
Level 1

Monthly logger meter reading
Maximum 24 previous month values

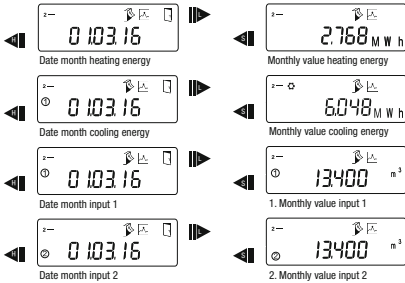

Legende



Press the button briefly (S), to switch through the display from top to bottom.

When having reached the last menu item the device automatically jumps back to the menu item at the top (loop).



Press the button for about 2 seconds (L), wait for the door symbol to appear (upper right corner of the display) and then release the button.

The menu is then updated resp. switches to the sub-menu.



Hold down the button (H) until the device switches to another level or switches back from the sub-menu.

Disposal

Attention: This device contains a non-removable and non-rechargeable lithium battery. Batteries contain substances, which could harm the environment and might endanger human health if not disposed of properly.

To reduce the disposal quantity so as unavoidable pollutants from electrical and electronic equipment in waste, old equipment should be reused prior or materials recycled or reused as another form.

This is only possible if old equipment, which contains batteries or other accessories are disposed. Therefore please contact the department of your local authority which is responsible for waste disposal. Alternatively a waste disposal via ZENNER is possible.

Your local or municipal authority or the local waste disposal company can give you information relating the collection points for your used equipments.

Attention:

Do not dispose of the devices with domestic waste.

In this way, you will help to protect natural resources and to promote the sustainable reuse of material resources.



For any question, please contact info@zenner.com

The most up-to-date information about this product and of our installation notice can be found at www.zenner.com